

Product Descriptions

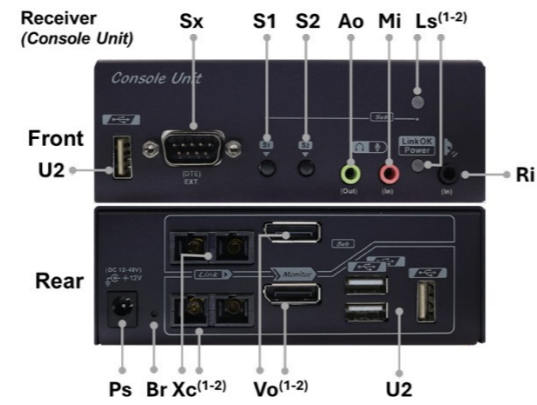
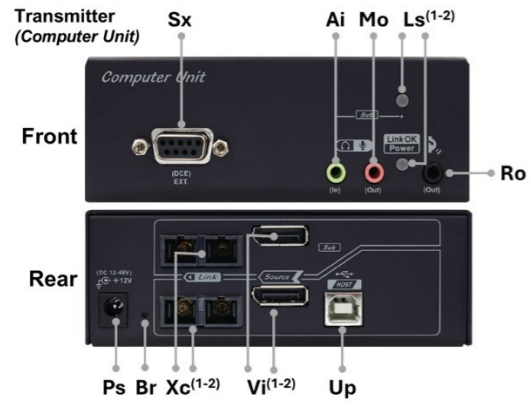

Label	Descriptions	
Vi ⁽¹⁻²⁾	Video Ext. (In)	Connect Vi ¹ to the Main (Primary) Video Out, and Vi ² to the 2 nd (Extended) Video Out of the PC.
Up	USB 2.0 Ext.	Connect to PC's USB 2.0 or 1.1 Port
Ai	Speaker Ext. (In)	Connect to PC's Speaker Output
Mo	Microphone Ext. (Out)	Connect to PC's MIC Input
Sx	Serial Ext. (DCE)	Connect to a DCE (Data Communication Equipment)
Ro	IR Ext. (Out)	Connect to an IR Blaster
Xc ⁽¹⁻²⁾	Fiber Link Ports	Connect to the corresponding Link Ports of the Receiver (Console unit) using two Duplex SC MMF
Ls ⁽¹⁻²⁾	Link OK / Power LED	Green : Transmitter Unit Power On Blue : Link OK
Br	Reset Button	Reset the Unit by clicking the Button
Ps	Power Supply	Apply proper power (DC 12~48V)

Label	Descriptions	
Vo ⁽¹⁻²⁾	Video Ext. (Out)	Connect Vo ¹ to Main (Primary) Monitor, and Vo ² to the 2 nd (Extended) Monitor
U2	USB 2.0 Ext.	Connect to USB KB/MS or other USB Devices
Ao	Speaker Ext (Out)	Connect to an Active Speaker
Mi	Microphone Ext. (In)	Connect to an Active Microphone*
Sx	Serial Extension (DTE)	Connect to a DTE (Data Terminal Equipment)
Ri	IR Ext. (In)	Connect to an IR Sensor
Xc ⁽¹⁻²⁾	Fiber Link Ports	Connect to the corresponding Link Ports of the Transmitter (Computer unit) using two Duplex SC MMF
Ls ⁽¹⁻²⁾	Link OK / Power LED	Red : Receiver Unit Power On Blue : Link OK
Br	Reset Button	Reset the Unit by clicking the Button
S1 & S2	Baud Rate Buttons	[S1]: Press to Select Baud Rate (in OSD) [S2]: Press to Call and Select OSD item
Ps	Power	Apply proper power (DC 12~48V)

Features

- Enables reliable remote access to a dual-monitor PC over two duplex SC multimode fiber cables, up to 1km
- Supports most popular resolutions on dual DP/HDMI video outputs, up to 4K@30Hz (4:4:4) or QHD@60Hz (4:4:4)
- USB 2.0 extension supports most USB devices
- IR extension from the console unit (Rx) to the computer unit (Tx)
- Serial extension supports industrial control applications
- Easy baud rate selection via OSD and push buttons
- EDID pass-through ensures accurate display information
- HDCP 1.4 compliant for uninterrupted 4K video playback
- Plug-and-play; no driver or software required
- Supports Windows, macOS, Linux, and Chrome OS
- Fiber link provides immunity to EMI and electrical noise
- Smart audio extension (audio auto embed/extract)

Package Contents

- 1 x Transmitter Unit
- 1 x Receiver Unit
- 2 x Power Adapters
- 1 x User Manual
- (Optional) 1 x IR Extension Kit (Blaster + Sensor)

System Requirements

- HDCP Compliant Monitors if transmitting HDCP-Protected Source
- USB Keyboard and Mouse
- DP/HDMI Video Cables and 3.5mm Audio Cables
- 3.5mm Active Speakers and Microphone
- USB Type A – Type B
- DB9 Serial Cables
- Duplex SC OM3 Multimode Fiber Cables

User Manual

4K30 Dual Head DP or HDMI KVM Fiber Extender With Audio, USB 2.0, IR, RS-232 Extension, Dual Duplex SC, Multimode 1Km



IPXF-DD430-DSC1K and IPXF-DH430-DSC1K User Manual

Ordering Information

Model	Video Ext. (Max. 4K30, 4:4:4)	IR Ext.	USB Ext.	Audio Ext.	Link Port
IPXF-DD430-DSC1K	HDMI 1.4 x 2	Rx-to-Tx	USB 2.0	3.5mm SPK 3.5mm MIC	Duplex SC x 2 (Multimode 1Km)
IPXF-DH430-DSC1K	DP x 2				

DSGio
DSGio Global Pte Ltd.
3 Lorong Bakar Batu #07-05
Singapore 348741

The final specification is based on the actual product.
Features and functions may be added or changed after the manual was written. Please visit our website to download the latest version of manual for reference.

IPXF-Dx430-DSC1K-UM01.0



Fiber Considerations

- For the interconnection between the RX (Console Unit) and the TX (Computer Unit), only Duplex SC connectors are supported. Two duplex multimode OM3 fibers are needed for the connection between the RX and TX unit.

The recommended fiber cable specifications and transmission distance are as follows:

Recommended Cable Type	Multimode
Specifications	OM3 / OM4
Diameter	50/125 μm
Max. Cable Length	1 Km
Connector	Duplex SC x 2

- Users should order cable lengths appropriate for their application environment; however, the maximum cable length should not exceed the specified length (refer to the table above) of the fiber cable. Exceeding the limit may cause signal degradation, especially the maximum video resolutions.
- Do not exceed the cable's bend radius. Fiber optic cables can break if kinked or bent too tightly, especially during installation or pulling.
- Do not twist the cable. Twisting can stress the fibers, and excessive tension or pulling forces may cause twisting.
- Do not look directly into the ends of any fiber optic cables. Exposure to invisible laser radiation may result in eye damage.
- Follow the cable manufacturer's recommendations. Fiber optic cables are often custom-designed for specific installations, and manufacturers may provide specific handling and installation instructions.

Installation

Before Installation

- Determine the locations of the RX (console unit) and the TX (computer unit).
- Use two duplex SC-to-SC fiber optic cables for the connection between the console unit and the computer unit.
- Ensure that the fiber cable is long enough to avoid the need for splicing. Try to complete the installation in a single pull.
- The extenders are HDCP-compliant. When connected to an HDCP-protected video source, an HDCP-compliant display must be used.
- Do not open or disassemble the enclosure. Doing so will void the warranty and may permanently damage the KVM extender, causing it to malfunction.
- Before installation, connect the PC directly to the monitor and KB/MS to ensure they are working properly.

Installation

- Connect the TX (computer unit) to the computer using the appropriate USB and video cables.
- Connect the RX (console unit) to the keyboard, mouse, and monitors using the appropriate USB and video cables.
- If the analogue audio extension function is being used, connect the TX unit to the computer using 3.5mm audio jack cables, and connect the RX unit to an active speaker and microphone.
- If the IR extension function is being used, connect the IR blaster to the TX unit and the IR receiver to the RX unit.
Note: The IR Extension Kit is not included in standard package. It needs to be ordered separately.
- Link the TX unit and RX unit using two duplex multimode fiber cables with duplex SC connectors.
Note: The two link ports on the TX and RX units must be connected to their corresponding ports; port 1 on the TX connects to port 1 on the RX, and port 2 on the TX connects to port 2 on the RX.
- Power on the units and all connected devices.

Connection Pattern

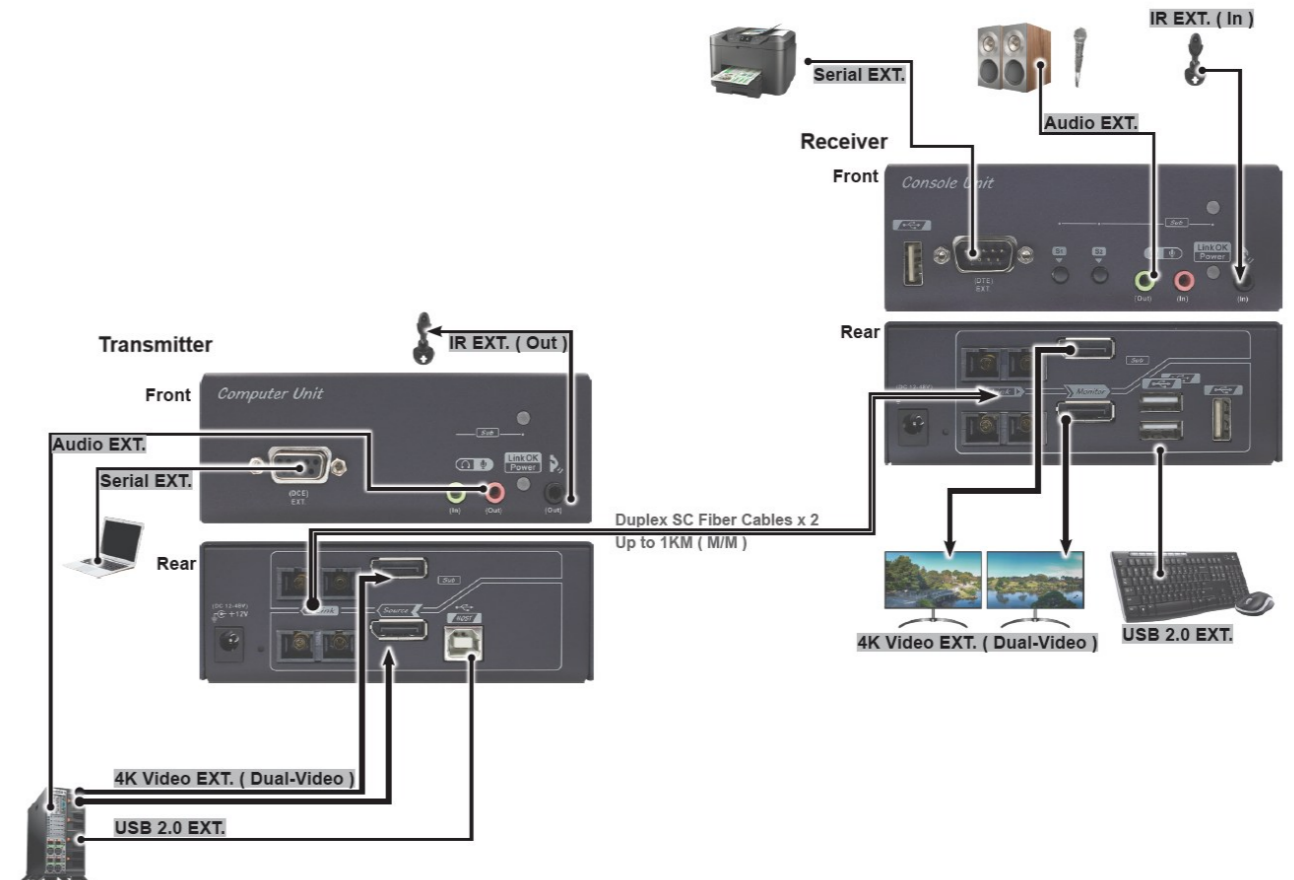

Operation

The LEDs on the extender units display the real-time status of the link and communication between the TX (console unit) and the RX (computer unit). Users can determine the current status through the LED indicators.

The quality of the output signal depends largely on the video source, cable, and display device used. Low-quality cables can degrade the output signal and cause increased noise levels. To ensure optimal performance, use high-quality cables and verify that the display device supports the selected resolution and refresh rate.

NOTE:

- The system will disable video output if it detects a non-HDCP-compliant display when playing HDCP-protected content.
- If the extenders are not directly connected via a continuous fiber run and instead terminate at patch panels, wall outlets, or faceplates at both ends, additional fiber patch cords are required.

In such cases, please note:

- Each additional connection point introduces insertion loss, which may reduce the maximum supported transmission distance.
- It is essential to use patch cords that match the type and specifications of the Link Ports (i.e., OM3/OM4 850nm multimode duplex SC patch cords).

Always ensure that all fiber components in the link — including permanent cabling and patch cords — are compatible with the optical wavelength and fiber mode of the Link Ports to maintain reliable performance.



Caution

Do not look directly into the ends of fiber optic cables or stare into the optical ports. Before performing any work on fiber optic connectors, transceivers or optical ports, ensure the device is powered off and no active laser source is present. Exposure to invisible laser radiation may occur and can cause serious eye injury.

Baud Rate Setting (Serial EXT.)

The serial extension requires the user to configure the correct baud rate for proper functionality.

Follow the steps below to configure the correct baud rate:

- Find out the correct baud rate of your serial device. (Refer to its manual.)
- Press S2 to open the OSD menu.
- Press S2 repeatedly to navigate to the 'Baud Rate' field.
- Press S1 repeatedly to select the correct baud rate for the device.
- After the correct baud rate is shown, wait until the OSD Fades Out.

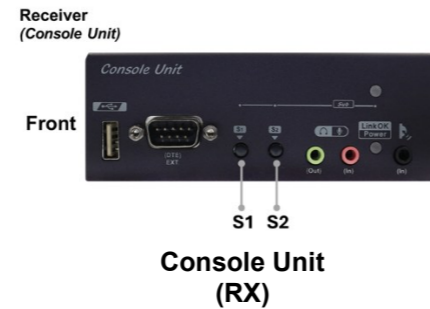

Smart Audio Extension (Auto Embed / Extract)

Smart Audio Extension

The KVM extender features a smart audio extension channel which can intelligently switch between HDMI/DP audio and speaker/microphone (SPK/MIC) extension. When SPK/MIC is connected, it takes priority over HDMI/DP audio, and HDMI/DP audio will be automatically disabled.

There are 2 situations:

1. < TX Audio In > Auto Embed

Whenever the TX (computer unit)'s SPK Input or MIC Output is inserted, the SPK input will be embedded into the digital audio stream of Video Input 1.

2. < RX Audio Out > Audio Extract

Whenever the RX (console unit)'s SPK Output or MIC Input is inserted, the SPK Output channel will be extracted from the digital audio stream of Video Output 1.

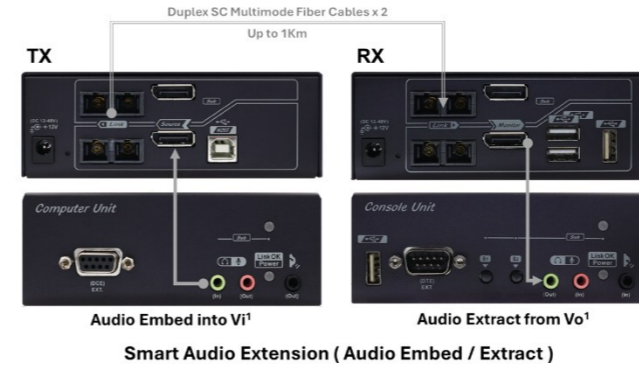

Specifications

IPXF-DD430-DSC1K / IPXF-DH430-DSC1K	Transmitter	Receiver
Max. Resolution*	4096x2160@30Hz (4:4:4) 3840x2160@30Hz (4:4:4)	
Video Interface	DD430: DisplayPort x 2 DH430: HDMI x 2	DD430: DisplayPort x 2 DH430: HDMI x 2
USB 2.0 Extension	USB 2.0 Type-B x 1	USB 2.0 Type-A x 1 (Front) USB 2.0 Type-A x 3 (Rear)
Speaker Extension	3.5mm SPK Jack x 1 (In) Supports Audio Embed	3.5mm SPK Jack x 1 (Out) Supports Audio Extract
Microphone Extension	3.5mm MIC Jack x 1 (Out)	3.5mm MIC Jack x 1 (In)
Serial Extension (9600 – 115200bps)	DB9 x 1 (RS-232 DCE)	DB9 x 1 (RS-232 DTE)
IR Extension	3.5mm x 1 (Out)	3.5mm x 1 (In)
Push Buttons	Reset x 1	Reset x 1 Baud Rate Button x 2
Status LED Indicators	Status x 2	Status x 2
HDCP Compliance	HDCP 1.4	
Fiber Link Port (1.25Gbps, 850nm)	Duplex SC x 2 (OM3 Multimode, 50/125µm)	
Extension Range	1 Km (SC, Multimode)	
Power Supply	DC 12V ~ 48V	
Operating Environment**	Temperature 0 ~ 40°C, Humidity < 80%	
Storage Temperature	-20 ~ 60°C	
Material	Aluminium	
H x W x D (mm)	44 x 122 x 140	
Weight (g)	400	450

* The extender supports most common resolutions. Monitors with non-standard or special EDIDs may not function correctly.

**When installing the units in a sealed enclosure, ensure adequate airflow to maintain proper operating temperature



Limited Warranty

IN NO EVENT SHALL THE DIRECT VENDOR'S LIABILITY FOR DIRECT OR INDIRECT, SPECIAL, INCIDENTAL OR CONSEQUENTIAL DAMAGES, LOSS OF PROFITS, LOSS OF BUSINESS, OR FINANCIAL LOSS CAUSED BY THE USE OF THE PRODUCT EXCEED THE PRICE PAID FOR THE PRODUCT.

The direct vendor makes no warranty or representation, expressed or implied, with respect to the contents or use of this documentation, and expressly disclaims its quality, performance, merchantability, or fitness for any particular purpose.

The direct vendor also reserves the right to revise or update the product or documentation without obligation to notify any user of such revisions or updates. For further information, please contact your direct vendor.

All brand names and registered trademarks are the property of their respective owners.